

ICE

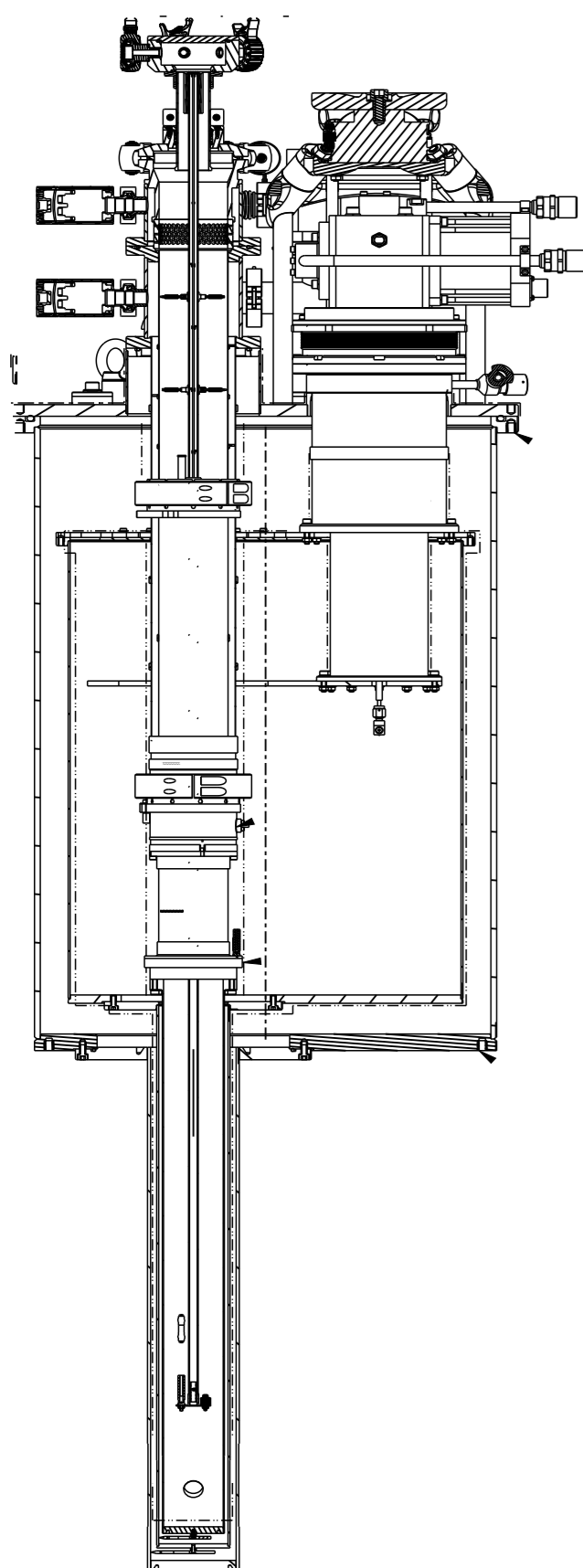

KEY FEATURES

- <1.3K base temperature continuous cryogen free operation
- Full temperature range : 20mK to 800K
- Patented Dual-cool technology allows sample cooldown in <30 mins to 1.5K
- 3He and Dilution insert compatible
- Remote and fully automated operation via supplied ICE Software

TEMPERATURE OPTIONS

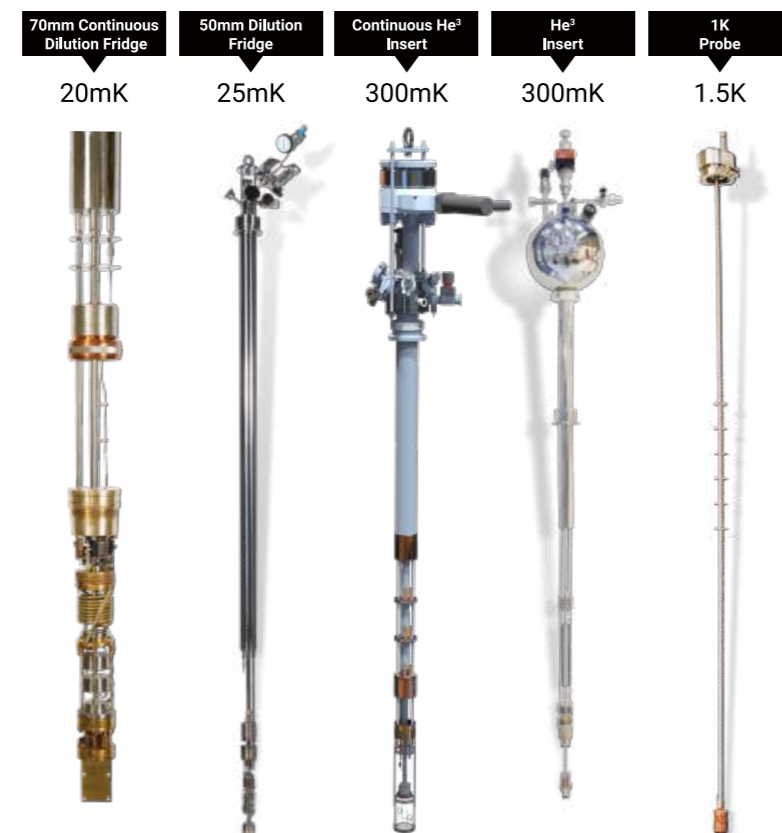

SAMPLE HOLDER POSSIBLE MOTION DIRECTIONS

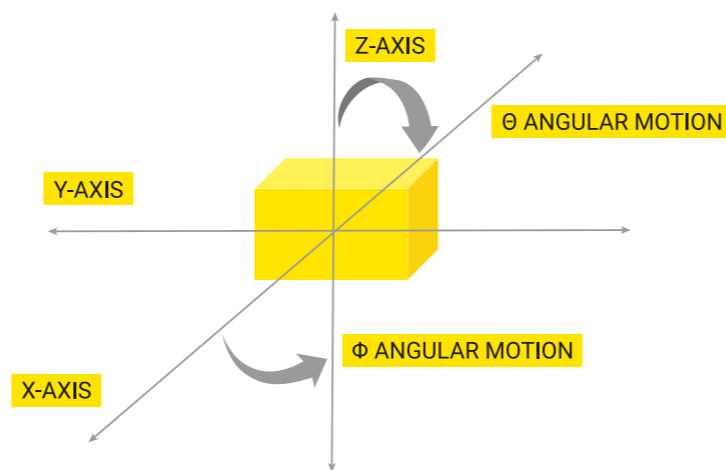

Precision-Cooled, High-Performance Probe Design

Top-loading probe inserts via a sliding-seal flange, precisely positioning the sample at the field centre. Radiation baffles and a thin stainless steel tube minimise heat load and conduction.

Smart Access & Temperature Control

Copper sample holder with a fire rod heater & sensor; top housing enables easy room-temperature access to the sample region.

Flexible Configuration

Supports exchange gas cooling and can be customised for vacuum. High-temp options available up to 800K.

Custom Wiring Options

Wide choice of DC or COAX wiring with Fischer, SMA, or other connectors—fully tailored to your setup.

AUTOMATED ROTATION STAGE FOR CRYOSTAT TOP FLANGE

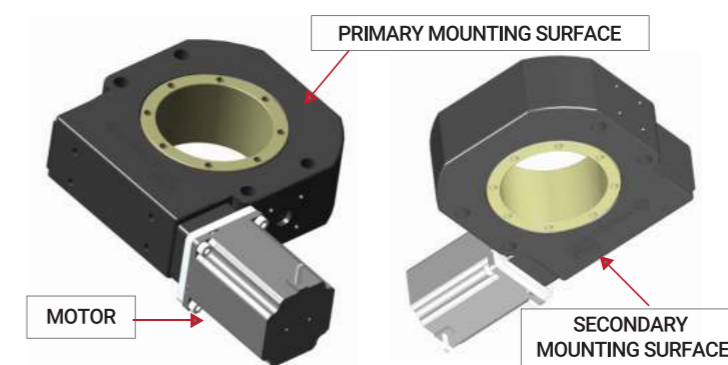

High-Precision Motorised Rotation Stages

ICEoxford uses advanced motorised worm gear stages offer improved speed, load capacity, and long-term accuracy. Available in both continuous and limited travel versions.

Lightweight & Robust Engineering

Constructed from aluminium alloy for weight savings and strength—ideal for multi-axis setups. Precision bearings ensure low error motion and high load capacity in a compact form.

Seamless Integration & Automated Control

Compatible with ICEoxford & existing inserts up to 100 mm in diameter, providing 360° automated rotation with 180 arcsecond accuracy. Supplied with a full mounting kit for easy integration at the probe entry point.

A: Z-AXIS PROBE WITH COARSE ROTATION

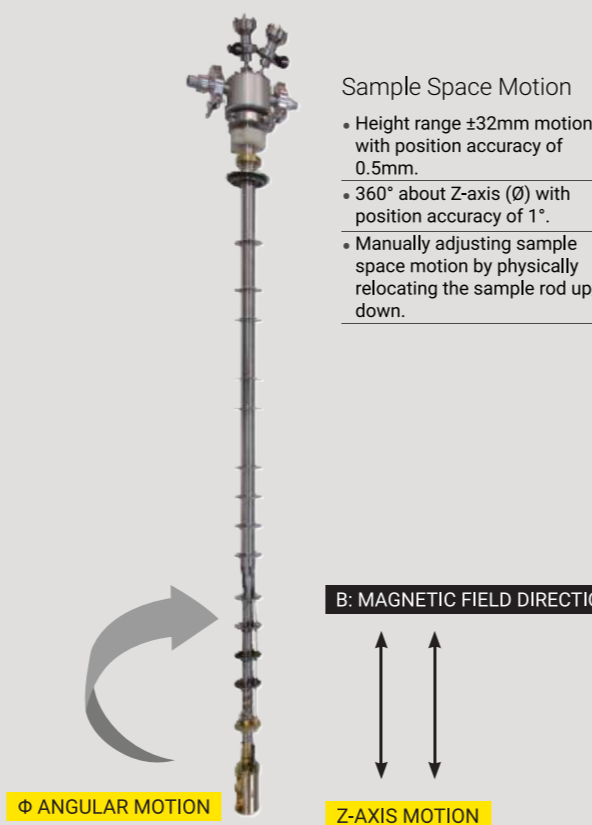

- Sample Space Motion
- Height range ± 32 mm motion with position accuracy of 0.5mm.
 - 360° about Z-axis (θ) with position accuracy of 1°.
 - Manually adjusting sample space motion by physically relocating the sample rod up/down.

B: Z-AXIS PROBE WITH ACCURATE ROTATION

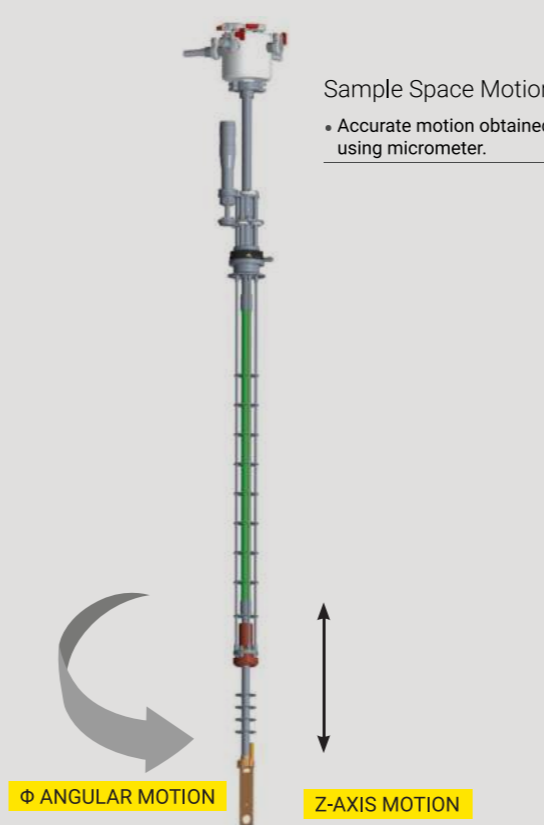

- Sample Space Motion
- Accurate motion obtained using micrometer.

C: X-AXIS PROBE WITH AUTOMATED ROTATION STAGE

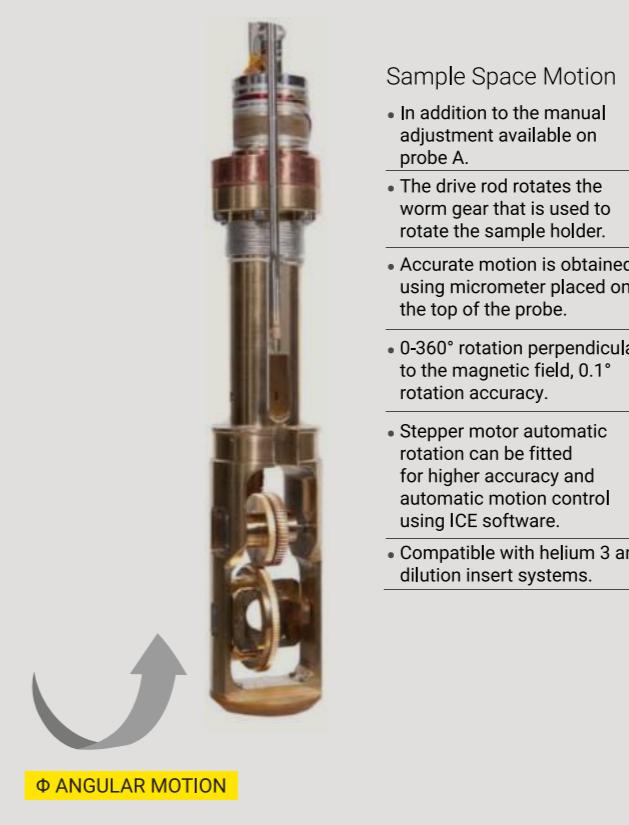

- Sample Space Motion
- In addition to the manual adjustment available on probe A.
 - The drive rod rotates the worm gear that is used to rotate the sample holder.
 - Accurate motion is obtained using micrometer placed on the top of the probe.
 - 0-360° rotation perpendicular to the magnetic field, 0.1° rotation accuracy.
 - Stepper motor automatic rotation can be fitted for higher accuracy and automatic motion control using ICE software.
 - Compatible with helium 3 and dilution insert systems.

D: Z-AXIS AND X-AXIS PROBE

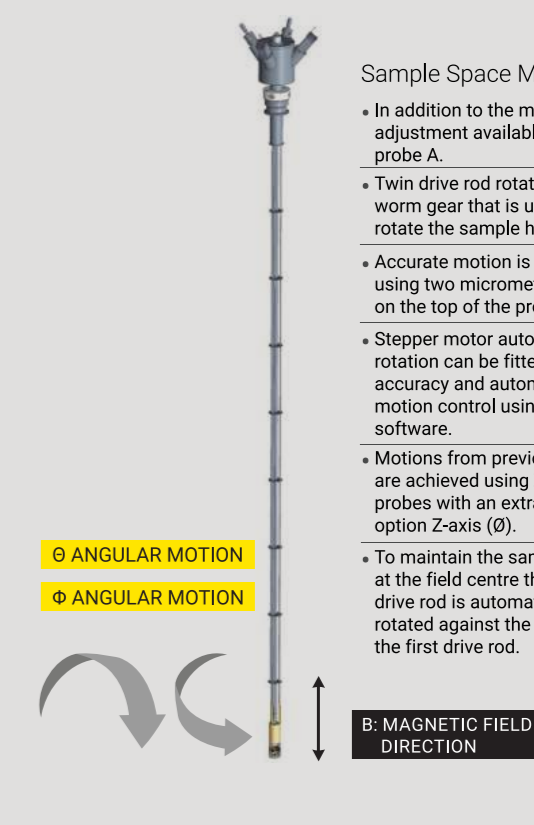

- Sample Space Motion
- In addition to the manual adjustment available on probe A.
 - Twin drive rod rotates the worm gear that is used to rotate the sample holder.
 - Accurate motion is obtained using two micrometers placed on the top of the probe.
 - Stepper motor automatic rotation can be fitted for higher accuracy and automatic motion control using ICE software.
 - Motions from previous probes are achieved using Z&X axis probes with an extra rotation option Z-axis (θ).
 - To maintain the sample position at the field centre the second drive rod is automatically counter rotated against the motion of the first drive rod.

ISIS Facility - Installed 2013

- Institute: Rutherford Appleton Labs, UK
- Description: Fully Automatic Dilution Refrigerator System for the Muon Beamline
- Specification: 70mm diameter dipper - 15mK Base Temperature, 40 μ W @100mK

The ISIS facility operates a VTI with a 70mm dilution refrigerator insert. This customised system was designed to be easily transported around the ISIS facility and allow fast turnaround mK experiments.

It also allowed experiments from the mK range to 300K within the same cryostat. It also had complex experimental wiring added and achieved the best base temperature and cooling power within such a compact design



Shanghai ARPES - Installed 2024

- Institute: Shanghai Tech University
- Description: DRY ICE™ bottom loading large sample space system
- Specification: 1.6K - 300K, 200mW @ 1.7K

The Shanghai Synchrotron facility operates a High Cooling power 1.7K cryostat with 200mW of cooling power to overcome the heat-loads generated by the ARPES beamline.

This customised system was designed to be UHV compatible and with 4 or 6 axis of UHV manipulation whilst maintaining a low precession movement of <0.5 mm off axis during manipulation. The sample is mounted on a modified standard sample holder to allow sample exchange by raising the insert up into the sample exchange position using UHV bellow and manipulators. The system provided the highest cooling power @ sub 2K available in a commercial DRY ARPES cryostat.

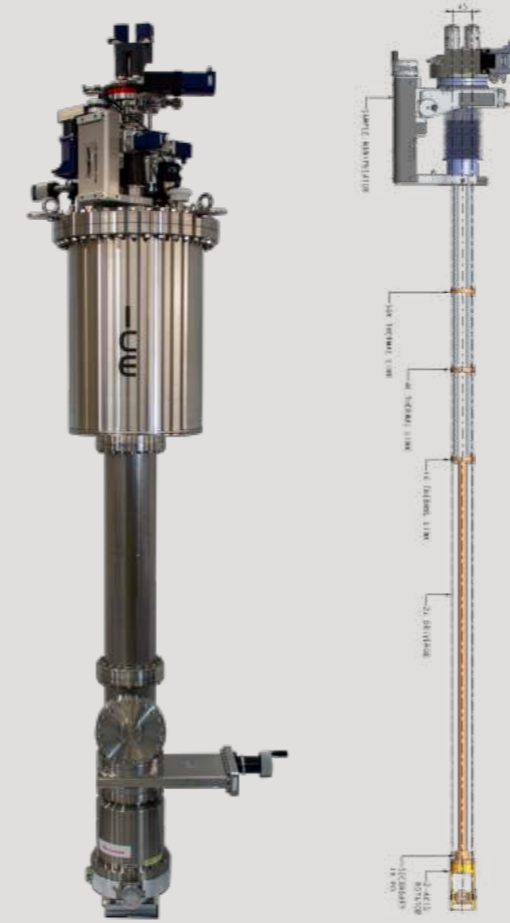

ICE

BEAMLINE CRYOSTATS

20mK to 800K



Lujan Neutron Scattering Center - Installed 2013

- Institute: Los Alamos National Laboratory
- Description: DRY ICE 1.5K with 50mm Probe
- Specification: 1.4K - 300K Variable Temperature Insert

The Los Alamos National Laboratory operates a VTI with a 7T split pair magnet. This system has two 1.5K probe inserts as well as a Helium 3 insert.

The system achieved a base temperature of 1.5K on both probes and a base temperature of 295mK on the Helium 3 insert. The high access 7T split pair magnet allows for a wide range of scattering angles, to suit your neutron beam.



TRIUMF

- Institute: TRIUMF
- Description: DRY ICE 1.5K 70mm Cryogen-Free Top-Loading
- Specification: 1.4K - 300K Variable Temperature Insert <20mK Dilution Insert

The TRIUMF M9H Muon Beamline system utilises an elongated 1.5K VTI with a pair of <20mK dilution inserts to allow for rapid sample exchange.

This cryogenic insert was designed to integrate with a high specification large bore / split superconducting magnet held within its own separate cryostat. The custom magnet allows access from 3 axes into a 4T magnet along with modulation coils for filed sweeping. The field stability and decay are important specifications for this system.

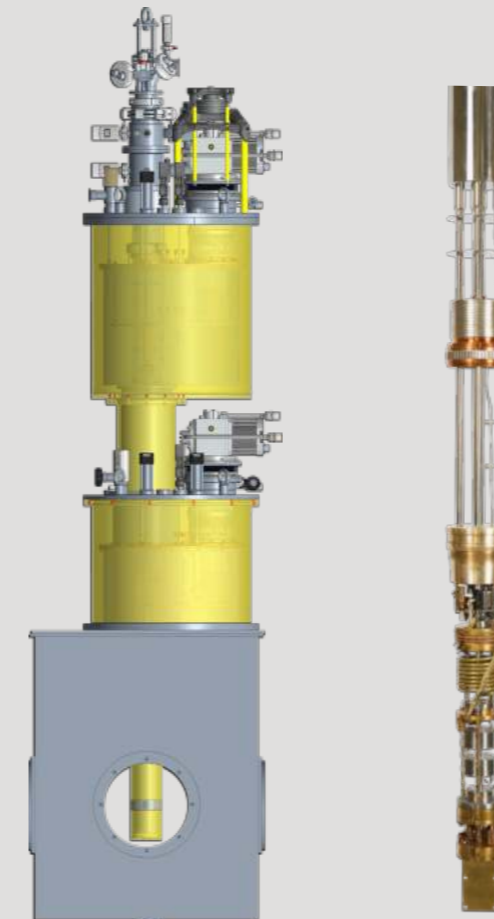

Our high performance beamline systems are engineered for precision, stability, and performance in ultra-low temperature environments.

Designed to integrate seamlessly with advanced research instruments, these systems ensure optimal cryogenic cooling, vibration control, and reliable sample handling. Ideal for Neutron, Muon, and X-ray applications, they deliver the performance and durability demanded.